

**ETF WEST LLC**  
Division of Energy Task Force LLC

---

## Pre-insulated pipe

2940 W Osborn Rd - Phoenix, AZ - 85017 - 407-523-3770 - 407-523-3722

### ETF-LT Product Specification

Piping system for LN<sub>2</sub>, CO<sub>2</sub>, O<sub>2</sub>, Ammonia, chilled water or process piping  
ETF-LT pre-insulated pipe shall consist of the following components:

- Carrier Pipe:** Type K hard drawn copper tubing conforming to ASTM-B-819 OXY MED in 20-foot lengths, Nitrogen purged, cleaned & capped. Or carrier pipe as specified.
- Insulation:** Polyurethane foam: K Factor 0.14, Density 2.0 to 3.0 PCF, 90-95% closed cell conforming to mil spec -1-24172 and ASTM-C-591 completely filling the annular space between carrier pipe and jacket. Maximum service temperature of 250°
- Jacketing Material:** High impact seamless polyvinyl chloride (PVC) class 12454 B compound conforming to ASTM 1784 Type 1, Grade 1. For jacket thickness see attached schedule
- End Seal:** Mastic end seal factory applied to insulation ends.
- Insulation of Straight Joints:** Prior to joining carrier pipe a PVC sleeve is slid onto jacketing on either side of joint. After soldering or brazing and hydro testing, the PVC sleeve is slid in place and sealed with pressure sensitive tape. Polyurethane foam is then mixed and poured into the annular space and sealed watertight.
- Fittings:** All fittings shall be contractor supplied; field Braised and insulated utilizing ETF fitting insulation kits. Fitting kits consist of hard-shell mitered PVC cover matching thickness of jacket, polyurethane foam and pressure sensitive tape.
- Backfilling:** Underground systems shall be buried in a trench of not less than 24 inches deeper than the top of the pipe jacket and not less than 18 inches wider than the combined O.D. of all piping systems. Backfill should be tamped compactly in place. No rock shall be used in the first foot of the backfill. To meet H-20 highway loadings, there must be 24 inches from top of jacket to grade of the compacted fill.

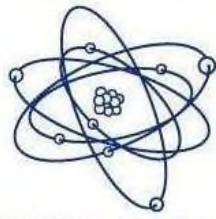

**ETF WEST LLC**  
 Division of Energy Task Force LLC

**Pre-insulated pipe**

7700 W Olive Ave - Peoria, AZ - 85345 - 623-878-4377 - 623-878-6683

**Table 1:** Specified Carrier Pipe / PVC Jacket

Nominal Pipe Size	Minimum Insulation Thickness	Nominal Jacket Size	Jacket Thickness
½"	1.7"	4.0	60 mils
½"	2.7"	6.0	70 mils
¾"	1.6"	4.0	60 mils
¾"	2.6"	6.0	70 mils
1"	1.4"	4.0	60 mils
1"	2.4"	6.0	70 mils
1 ¼"	1.3"	4.0	60 mils
1 ¼"	2.3"	6.0	70 mils
1 ½"	1.2"	4.0	60 mils
1 ½"	2.2"	6.0	70 mils
2"	1.9"	6.0	70 mils
2"	2.9"	8.0	80 mils
2 ½"	1.7"	6.0	70 mils
2 ½"	2.7"	8.0	80 mils
3"	1.4"	6.0	70 mils
3"	2.4"	8.0	80 mils

**ETF LLC WARRANTY**

ETF LLC warrants its products only to the extent that it will replace those proved to have manufactured defects, within a one-year period from date of delivery. ETF must be provided an opportunity to inspect an alleged defective product and the installation application. This warranty does not provide for the expenses incurred for removal, re-installation or consequential damages arising from the defective material. There is no warranty other than that described above, and no one is authorized to issue any other warranty related to ETF LLC products.

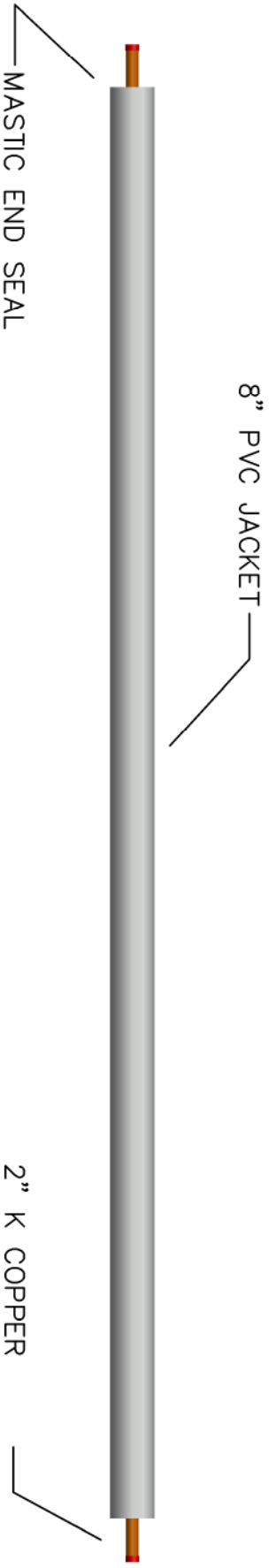

8" PVC JACKET

MASTIC END SEAL

2" K COPPER  
CLEANED & CAPPED

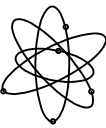
 <b>ETF WEST LLC</b> <b>PRE-INSULATED PIPE</b>		7700 W OLIVE AVE - PEORIA, AZ 85345 - 407-523-3770 - 407-523-3722		
SCALE	NTS	K COPPER C&C X PVC JACKET	DRAWN BY	LG
DATE	4/24/16		DWG #	

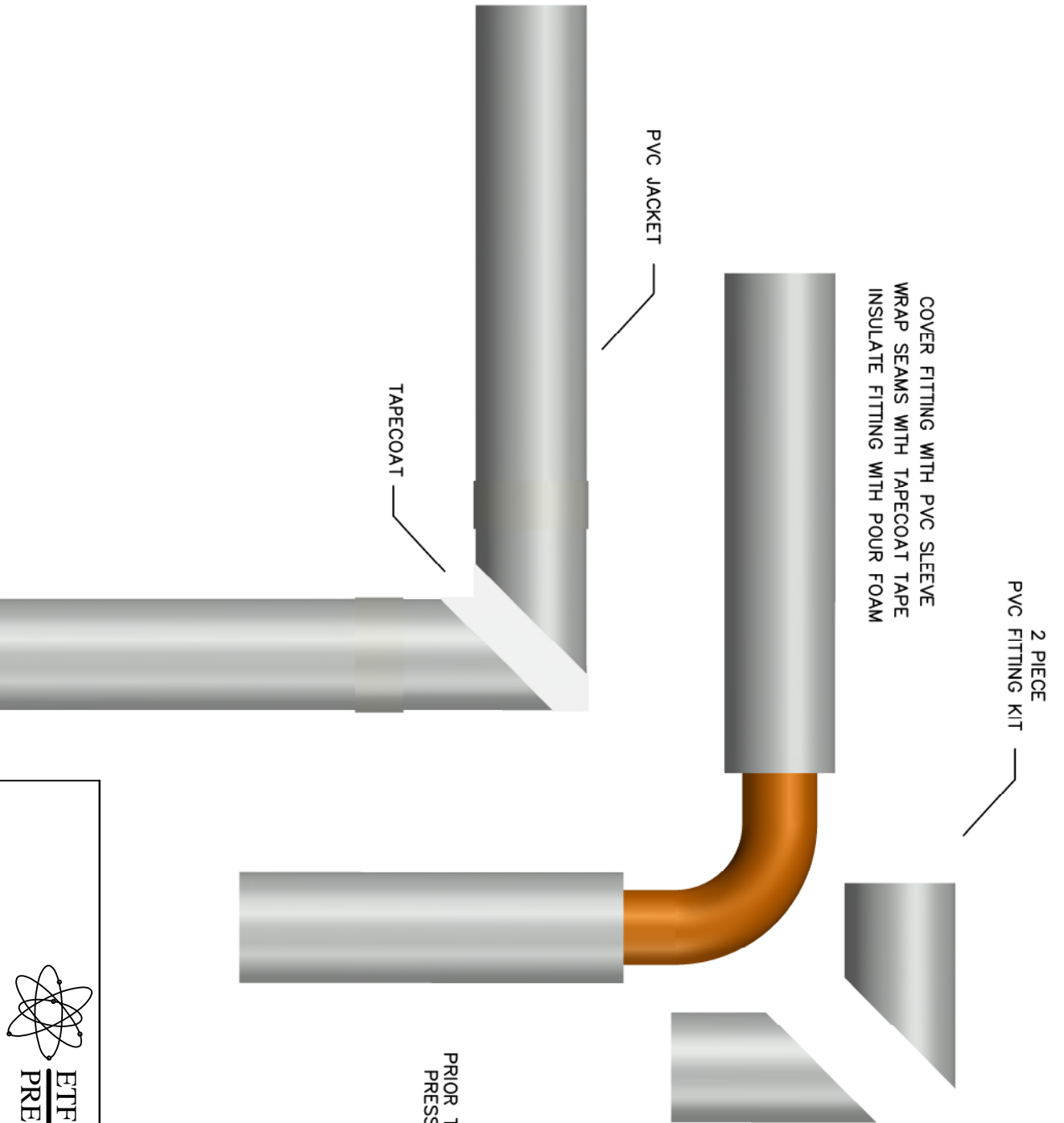

PRIOR TO INSULATING FITTING  
PRESSURE TEST SYSTEM

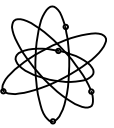

**ETF WEST LLC**  
**PRE-INSULATED PIPE**

2940 W OSBORN RD - PHOENIX, AZ 85017 - 407-523-3770 - 407-523-3722

SCALE NTS	DRAWN BY LG
DATE 5/25/16	
COPPER 90 INSULATION KIT	
DWG #	

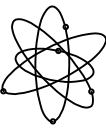
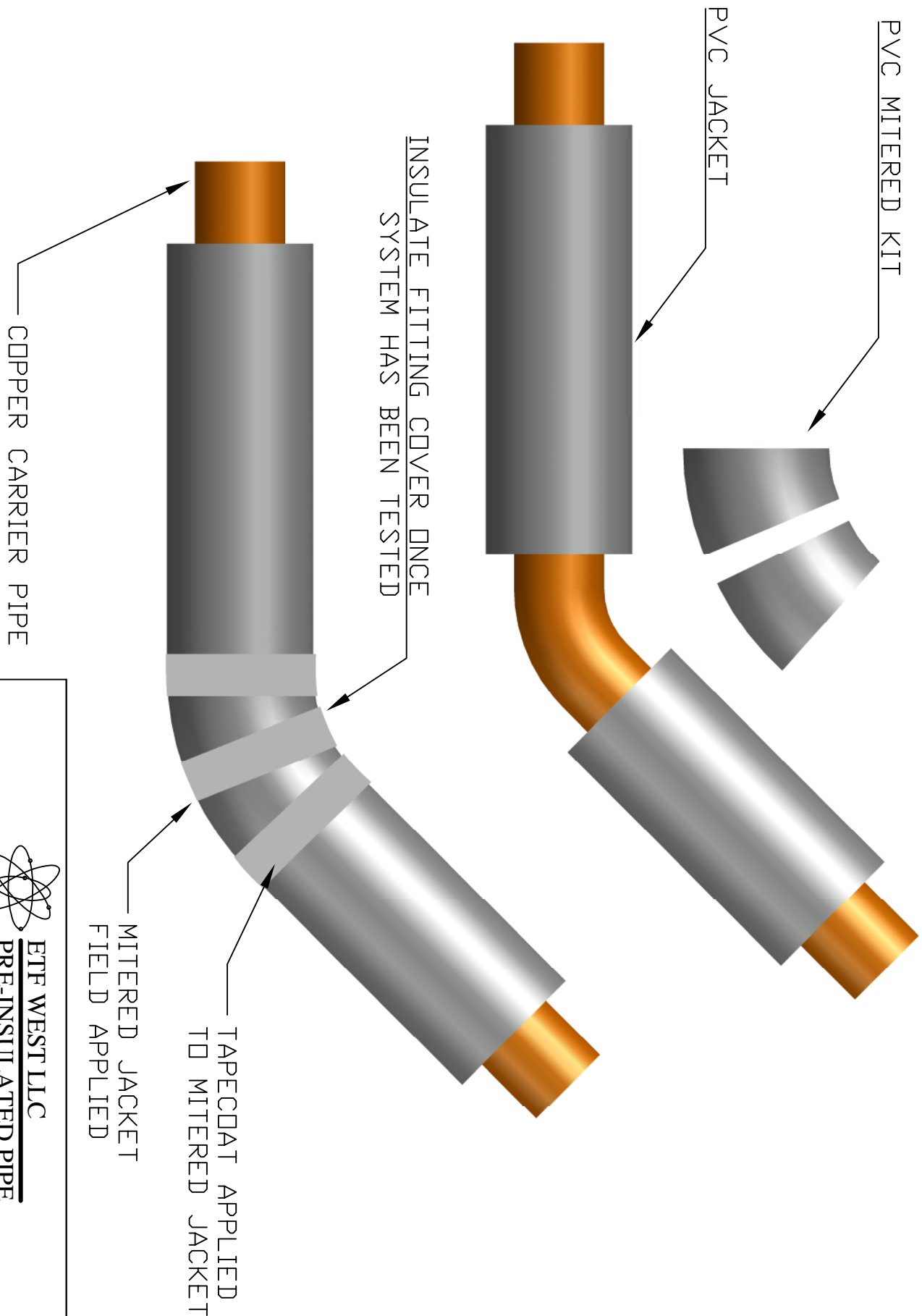

**ETF WEST LLC**  
**PRE-INSULATED PIPE**

2940 W OSBORN RD - PHOENIX, AZ 85017 - 407-523-3770 - 407-523-3722

SCALE NTS	FIELD INSULATED 45	DRAWN BY LG
DATE 4/22/16	COPPER X PVC JACKET	DWG #

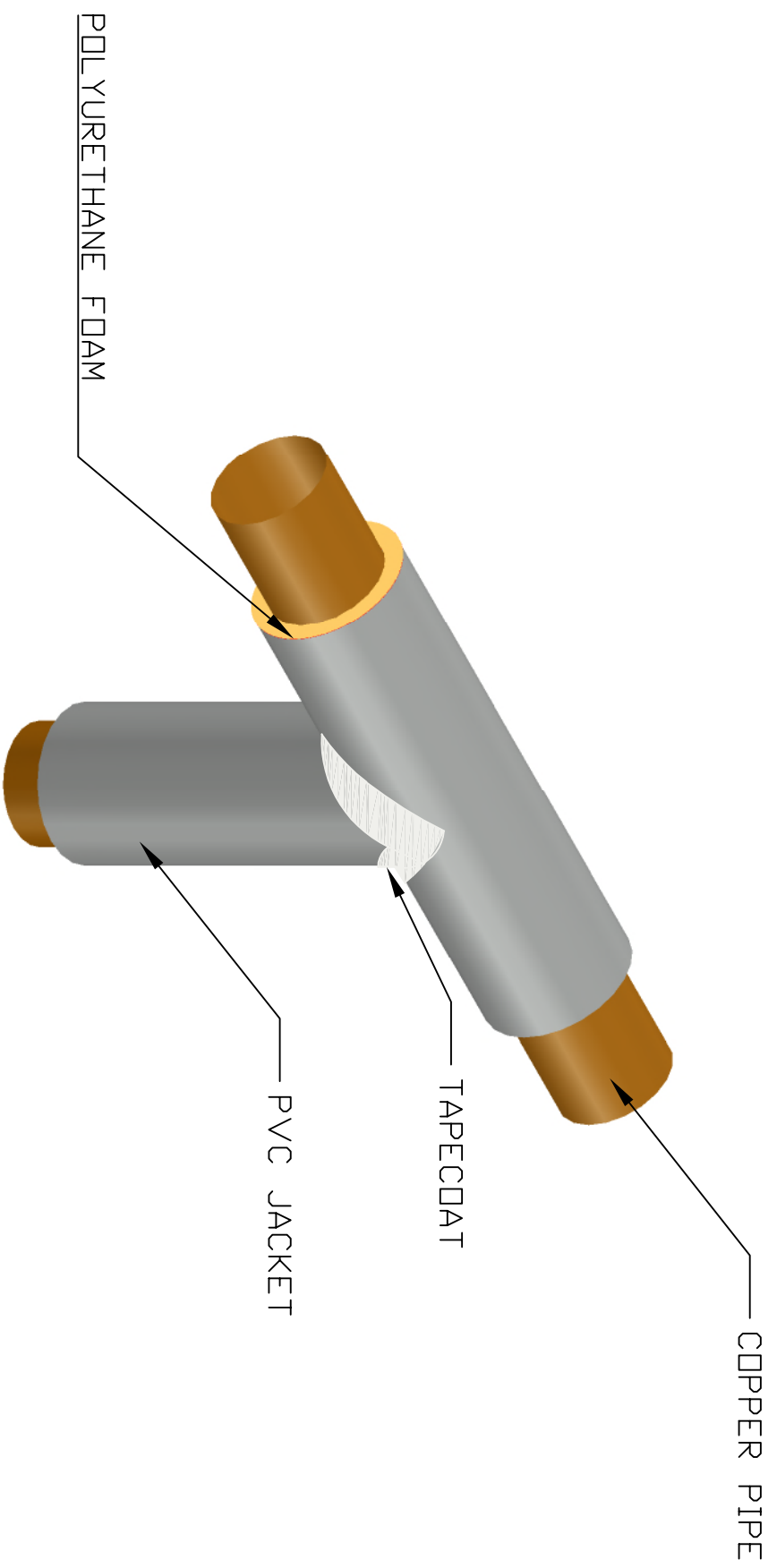

POLYURETHANE FOAM

COPPER PIPE

TAPECOAT

PVC JACKET

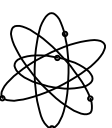

**ETF WEST LLC**  
**PRE-INSULATED PIPE**

2940 W OSBORN RD - PHOENIX, AZ 85017 - 623-878-4377 - 623-878-6683

SCALE AS SHOWN

DATE 6/10/16

STRAIGHT TEE

DRAWN BY LG  
 DWG #

PRIOR TO INSULATING JOINT  
PRESSURE TEST SYSTEM

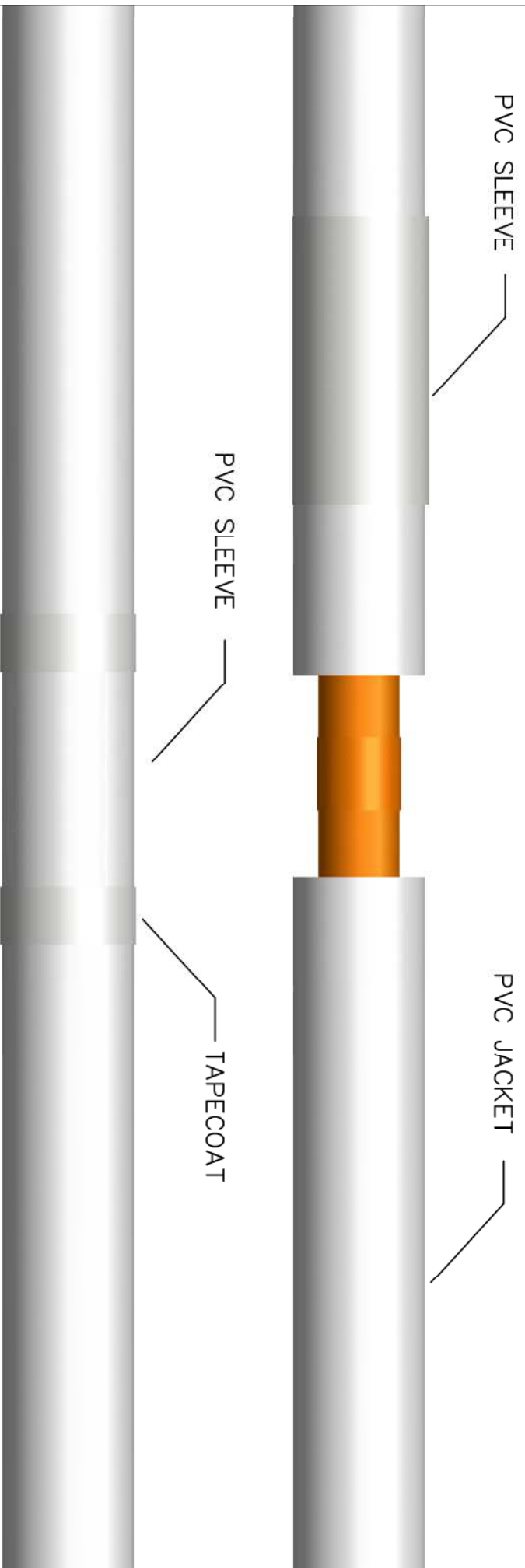

COVER JOINT WITH PVC SLEEVE  
WRAP SEAMS WITH TAPECOAT TAPE  
INSULATE JOINT WITH POUR FOAM

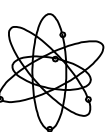

**ETF WEST LLC**  
**PRE-INSULATED PIPE**

7700 W OLIVE AVE - PEORIA, AZ 85345 - 407-523-3770 - 407-523-3722

SCALE  
NTS

DATE  
4/42/16

FIELD JOINT DETAIL

DRAWN BY  
LG

DWG #

# CONCRETE ANCHOR BLOCK

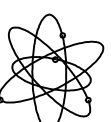
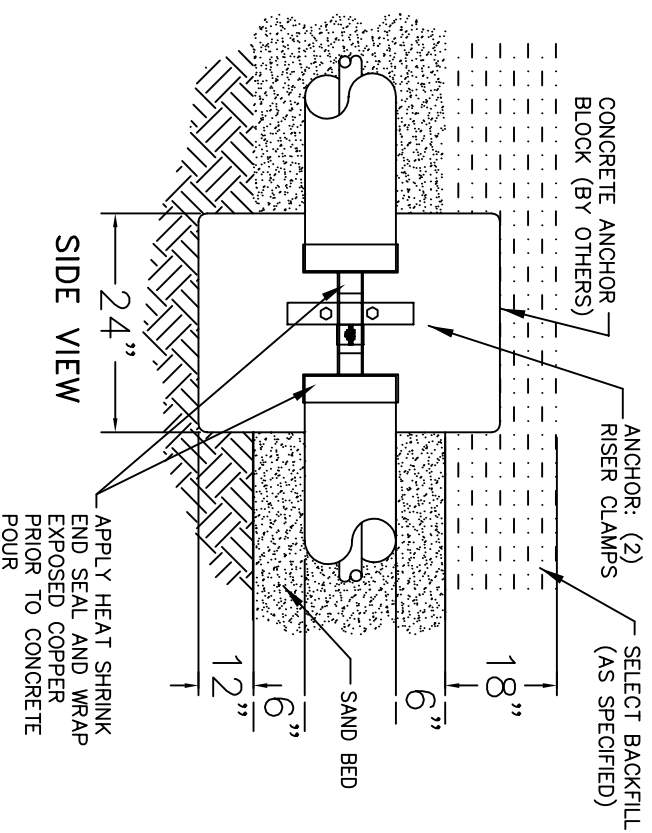
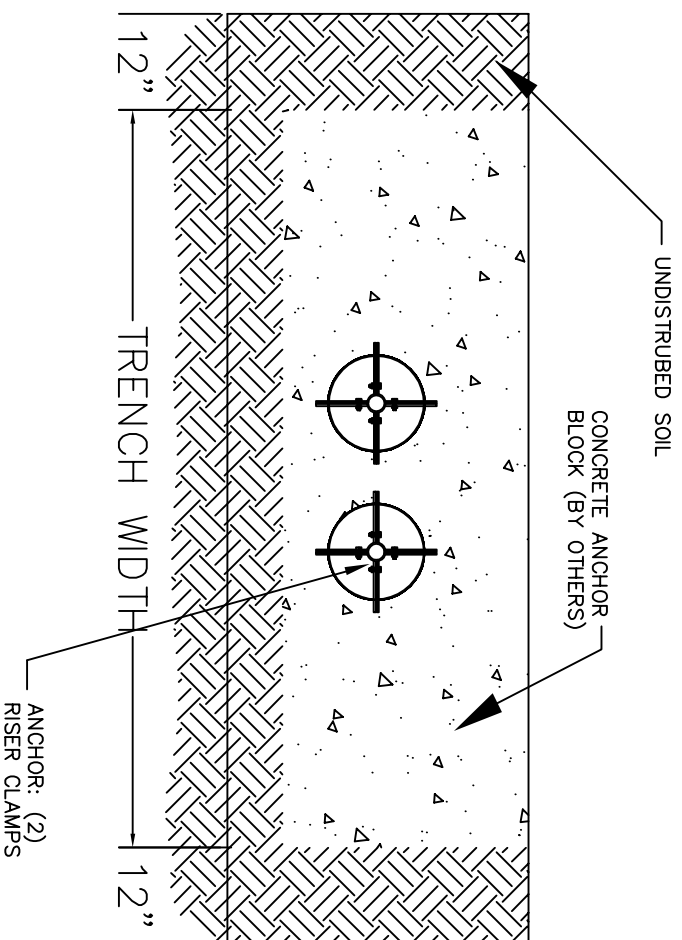

**ETE WEST LLC**  
**PRE-INSULATED PIPE**

7700 WEST OLIVE AVE. - PEORIA, AZ 85345 - 623-878-4377 - 623-878-6683

SCALE  
 NTS

DATE  
 8/2/04

COPPER ANCHOR

DRAWN BY  
 LG

DWG #