

ETF WEST LLC
Division of Energy Task Force LLC

Pre-insulated pipe

7700 W Olive Ave - Peoria, AZ - 85345 - 407-523-3770 - 407-523-2722

ETF-MT Product Specification

Pre-insulated piping system designed for above ground or direct buried Chilled Water, Hot Water and all other 45° to 250° medium temperature systems.

- Carrier Pipe:** Schedule 40 Steel A-53 ERW
- Insulation:** Polyurethane foam: K Factor 0.14, Density 2.0 to 3.0 PCF, 90-95% closed cell conforming to mil spec -1-24172 and ASTM-C-591 completely filling the annular space between carrier pipe and jacket. Maximum service temperature of 250°
- Jacketing Material:** High impact seamless polyvinyl chloride (PVC) class 12454 B compound conforming to ASTM 1784 Type 1, Grade 1. For jacket thickness see attached schedule
- End Seal:** Mastic material end seal factory applied to insulation ends.
- Insulation of Straight Joints:** Prior to joining carrier pipe a PVC sleeve is slid onto jacketing on either side of joint. After welding and hydro testing, the PVC sleeve is slid in place and sealed with pressure sensitive tape. Polyurethane foam is then mixed and poured into the annular space and sealed watertight.
- Fittings:** All fittings shall be Pre-fabricated / Pre-insulated by ETF.
- Backfilling:** Underground systems shall be buried in a trench of not less than 24 inches deeper than the top of the pipe jacket and not less than 18 inches wider than the combined O.D. of all piping systems. Backfill should be tamped compactly in place. No rock shall be used in the first foot of the backfill. To meet H-20 highway loadings, there must be 24 inches from top of jacket to grade of the compacted fill.

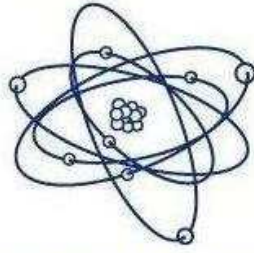

ETF WEST LLC
Division of Energy Task Force LLC

Pre-insulated pipe

7700 W Olive Ave - Peoria, AZ - 85345 - 407-523-3770 - 407-523-2722

Table 1: Specified Carrier Pipe / PVC Jacket

Nominal Pipe Size	Minimum Insulation Thickness	Nominal Jacket Size	Jacket Thickness
1/2"	1.27	3.5	60 mils
3/4"	1.16	3.5	60 mils
1"	1.03	3.5	60 mils
1 1/4"	1.17	4.0	60 mils
1 1/2"	2.07	6.0	70 mils
2"	1.81	6.0	70 mils
2 1/2"	1.56	6.0	70 mils
3"	1.25	6.0	70 mils
4"	1.75	8.0	80 mils
5"	1.22	8.0	80 mils
6"	1.69	10.0	100 mils
8"	1.69	12.0	120 mils
10"	1.64	14.0	140 mils
12"	1.63	16.0	160 mils

ENERGY TASK FORCE LLC WARRANTY

Energy Task Force LLC warrants its products only to the extent that it will replace those proved to have manufactured defects, within a one-year period from date of delivery. Energy Task Force must be provided an opportunity to inspect an alleged defective product and the installation application. This warranty does not provide for the expenses incurred for removal, re-installation or consequential damages arising from the defective material. There is no warranty other than that described above, and no one is authorized to issue any other warranty related to Energy Task Force LLC products.

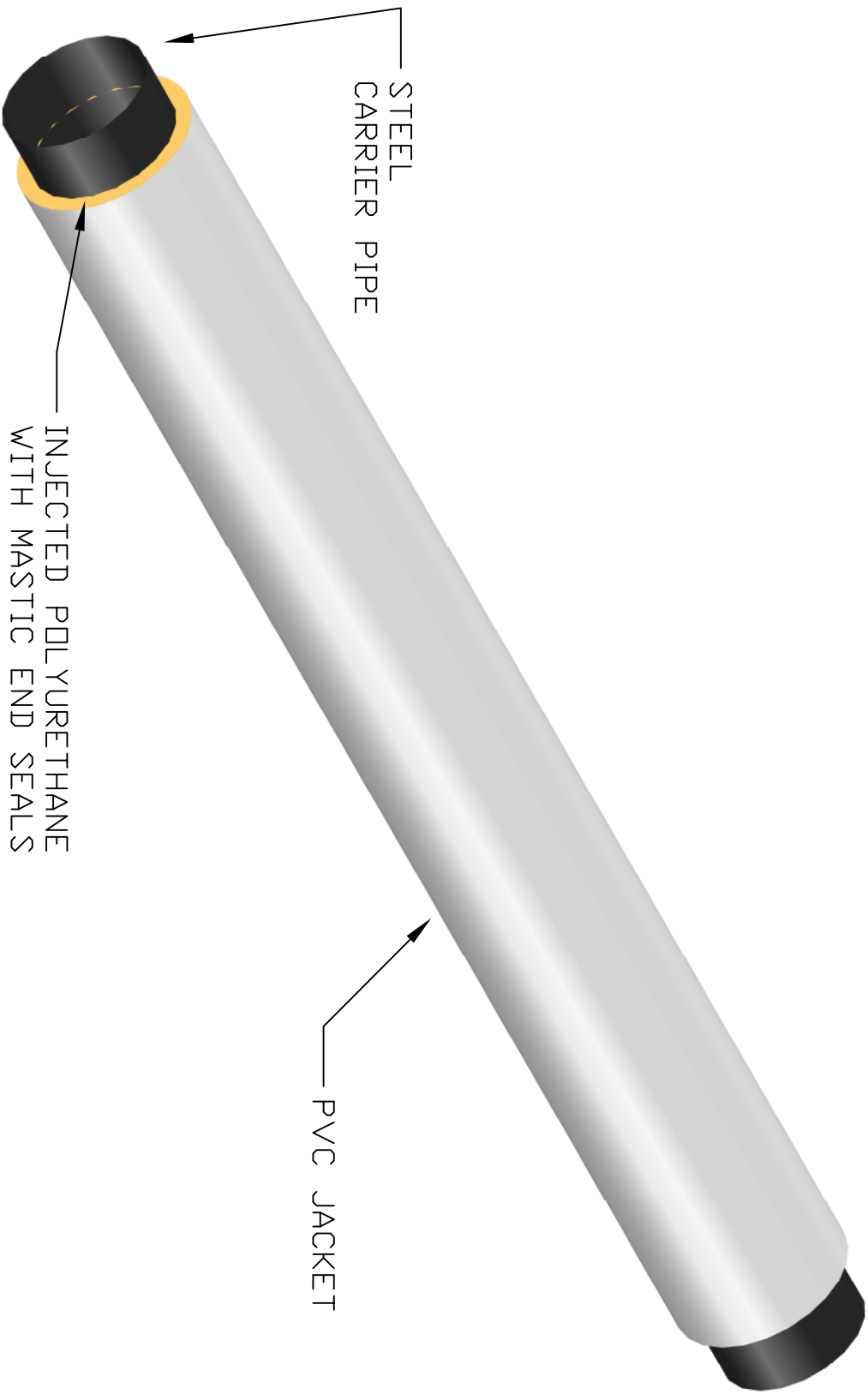

STEEL
CARRIER PIPE

INJECTED POLYURETHANE
WITH MASTIC END SEALS

PVC JACKET

7700 W OLIVE AVE - PEORIA, AZ 85345 - 407-523-3770 - 407-523-3722

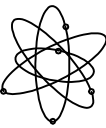

ETF WEST LLC
PRE-INSULATED PIPE

SCALE
NTS
DATE 4/22/16

STEEL X PVC JACKET

DRAWN BY
LG
DWG #

PIPE CAN BE 42' OR 21' LENGTHS

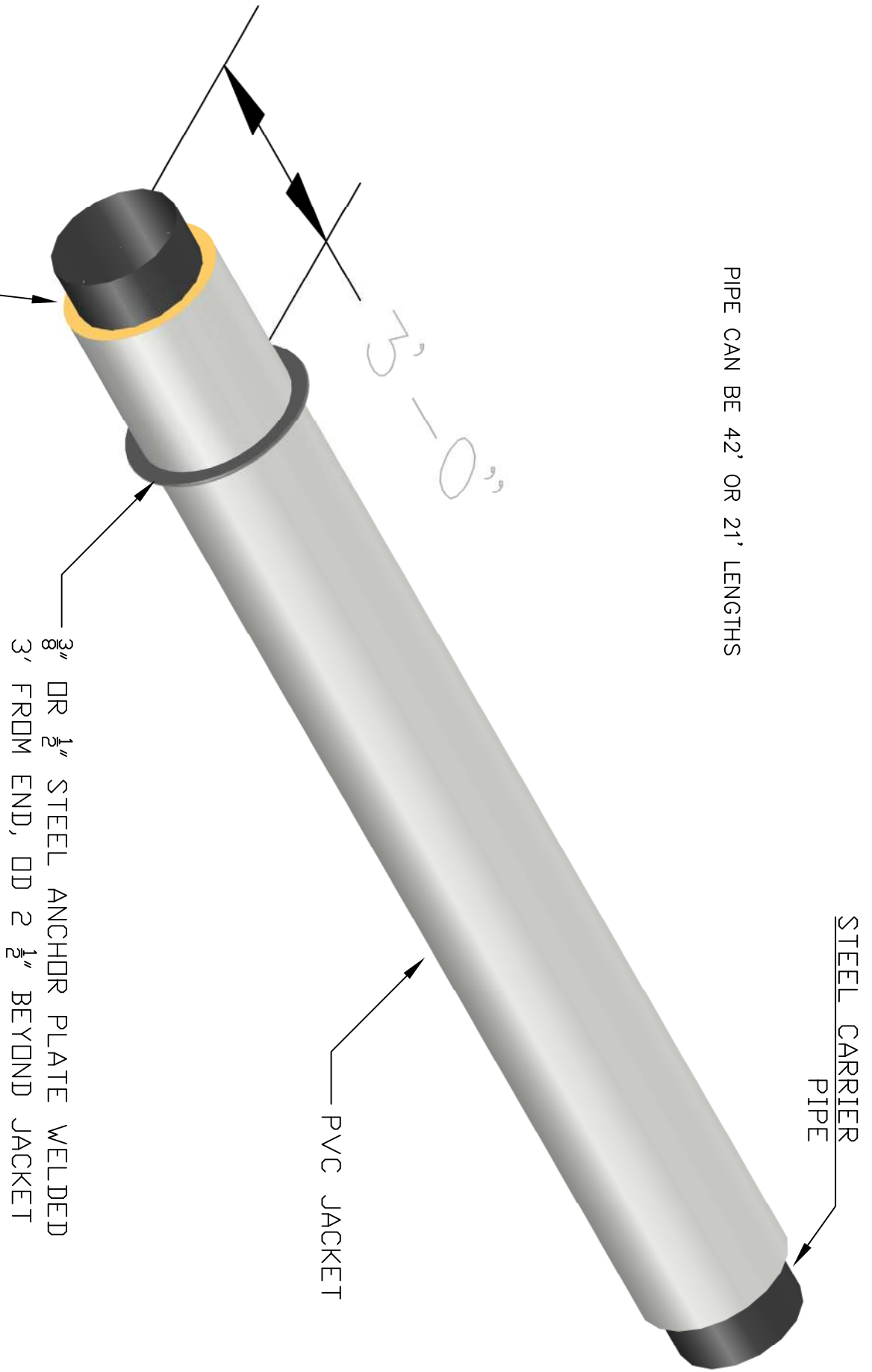

STEEL CARRIER
PIPE

PVC JACKET

3" OR 1 1/2" STEEL ANCHOR PLATE WELDED
3' FROM END, OD 2 1/2" BEYOND JACKET

INJECTED POLYURETHANE
WITH MASTIC END SEALS

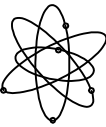
 ETF WEST LLC PRE-INSULATED PIPE		7700 W OLIVE AVE - PEORIA, AZ 85345 - 407-523-3770 - 407-523-3722	
		SCALE NTS	DATE 4/22/16
STEEL X PVC JACKET		DRAWN BY LG	DWG #

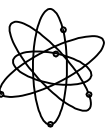
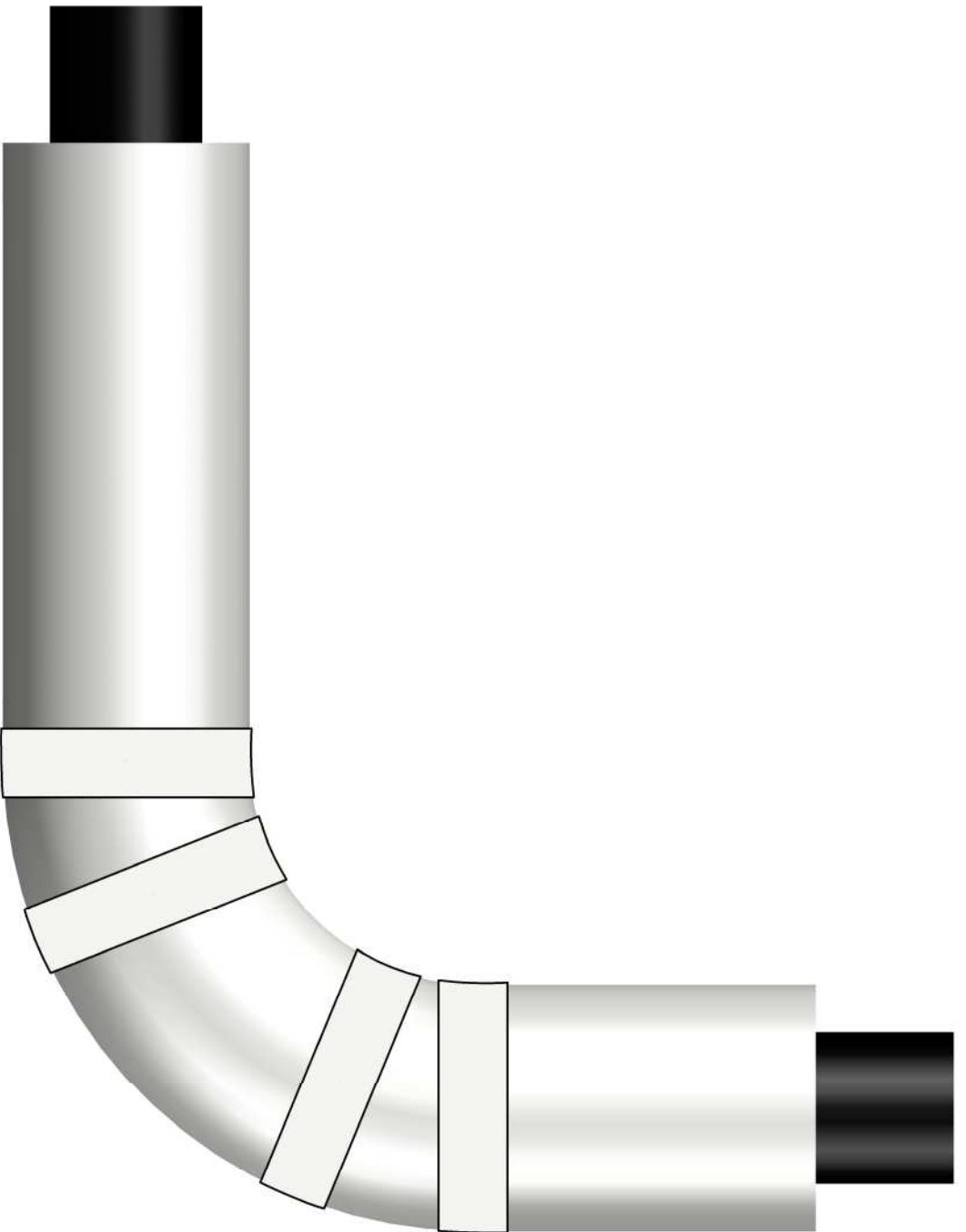

ETE WEST LLC
PRE-INSULATED PIPE

7700 WEST OLIVE AVE - PEORIA, AZ 85345 - 623-878-4377 - 623-878-6683

SCALE
NTS

DATE
8/2/04

PRE-INSULATED 90

DRAWN BY
LG

DWG #

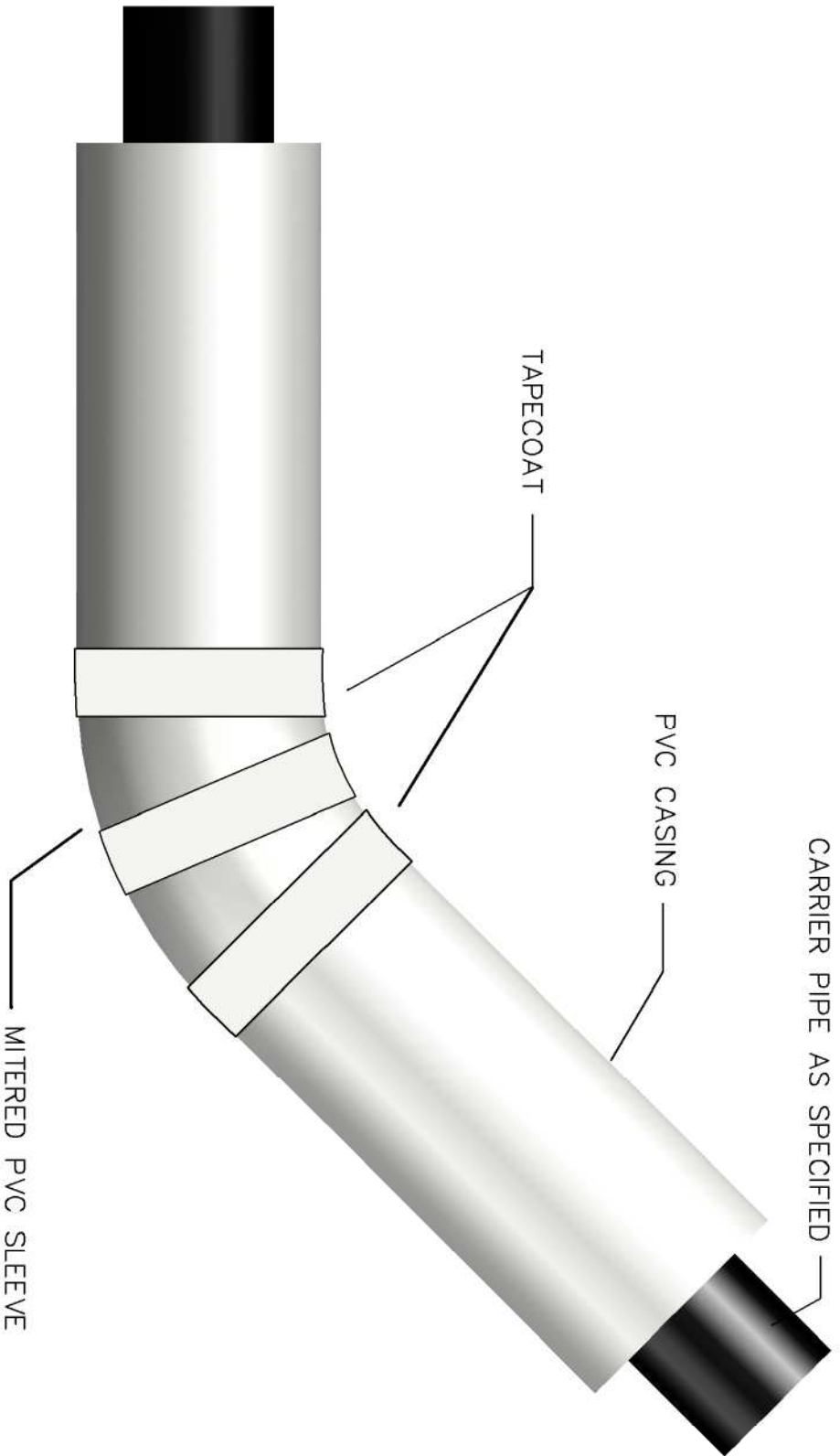

CARRIER PIPE AS SPECIFIED

PVC CASING

TAPECOAT

MITERED PVC SLEEVE

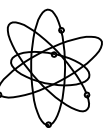

ETF WEST LLC
PRE-INSULATED PIPE

7700 WEST OLIVE AVE - PEORIA, AZ 85345 - 407-523-3770 - 407-523-3722

SCALE NTS

PREFABRICATED

DRAWN BY LG

DATE 8/2/04

45 DEGREE ELBOW

DWG #

THIS CAN BE MADE ROLLING TEE AT
AT A 45 AND ADDING A 45

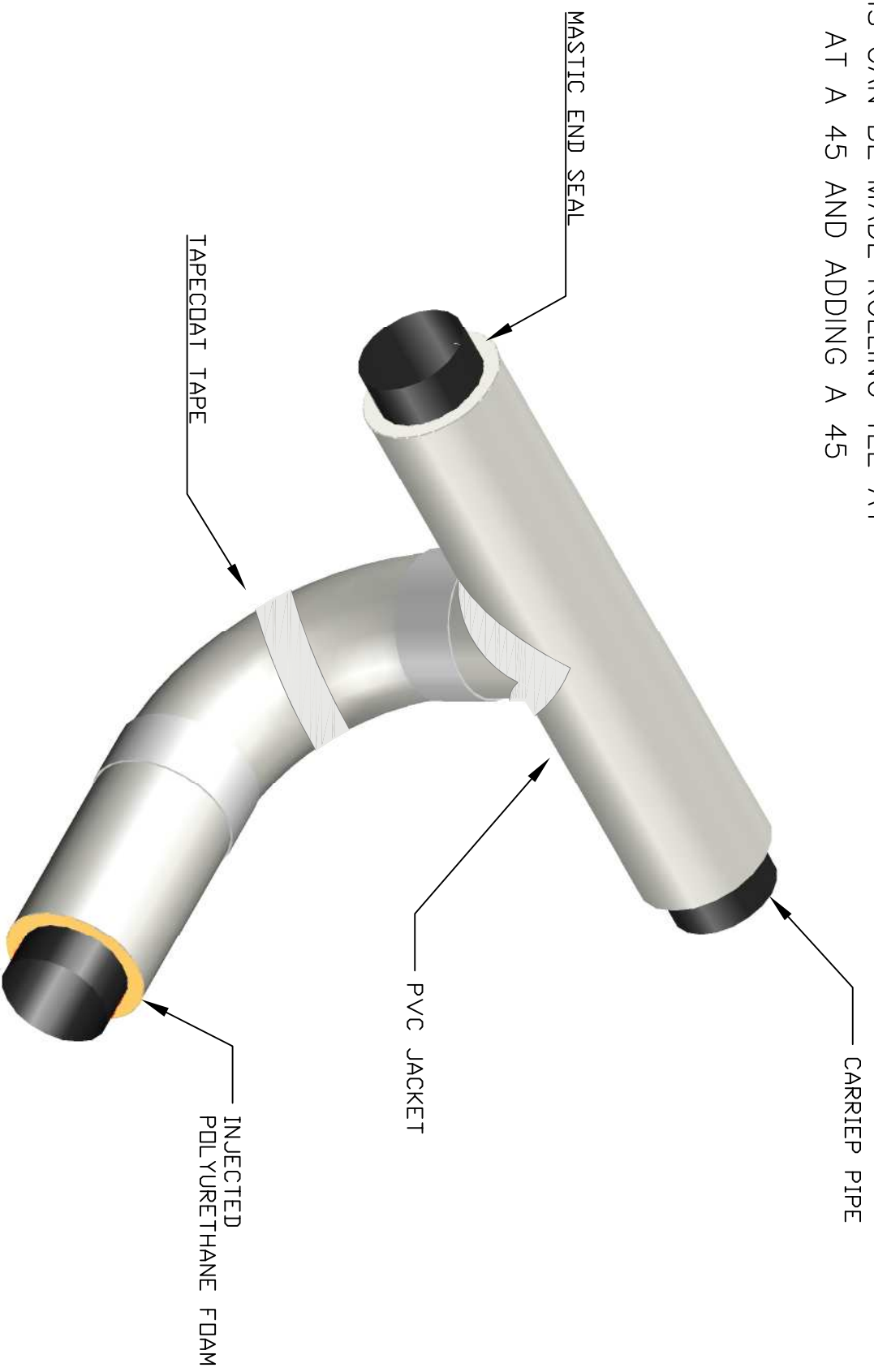

 ETF WEST LLC PRE-INSULATED PIPE		7700 WEST OLIVE AVE - PEORIA, AZ 85345 - 623-878-4377 - 623-878-6683
		SCALE AS SHOWN
DATE 6/10/15	CROSSOVER TEE	DRAWN BY LG
		DWG #

PVC
PRIOR TO INSULATING JOINT
PRESSURE TEST SYSTEM

PVC JACKET

PVC SLEEVE

TAPECOAT

COVER JOINT WITH PVC SLEEVE
WRAP SEAMS WITH TAPECOAT TAPE
INSULATE JOINT WITH POUR FOAM

7700 W OLIVE AVE - PEORIA, AZ 85345 - 407-523-3770 - 407-523-3722

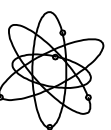

ETF WEST LLC
PRE-INSULATED PIPE

SCALE
NTS

DATE
8/2/04

FIELD JOINT DETAIL

DRAWN BY
LG

DWG #