

**ETF WEST LLC**  
Division of Energy Task Force LLC

## **Pre-insulated pipe**

7700 W Olive Ave - Peoria, AZ - 85345 - 623-878-4377 - 623-878-6683

### **ETF-MT Product Specification**

Pre-insulated piping system designed for above ground or direct buried Chilled Water, Hot Water and all other 30° to 250° medium temperature systems.

- Carrier Pipe:** Schedule 40 A53B ERW Steel.
- Insulation:** Polyurethane foam: K Factor 0.14, Density 2.0 to 3.0 PCF, 90-95% closed cell conforming to mil spec -1-24172 and ASTM-C-591 completely filling the annular space between carrier pipe and jacket. Maximum service temperature of 250°
- Jacketing Material:** High Density Polyethylene (HDPE) casing Type III, Category 5, Class C conforming to ASTM D-1248 or as specified. For jacket thickness see attached schedule
- End Seal:** Mastic factory applied to insulation ends.
- Insulation of Straight Joints:** Prior to joining carrier pipe an HDPE sleeve is slid onto jacketing on either side of joint. After welding and hydro testing, the HDPE sleeve is slid in place and sealed with heat shrink tape. Polyurethane foam is then mixed and poured into the annular space and sealed watertight.
- Fittings:** All fittings are Pre-fabricated and Pre-insulated by ETF West LLC
- Backfilling:** Underground systems shall be buried in a trench of not less than 24 inches deeper than the top of the pipe jacket and not less than 18 inches wider than the combined O.D. of all piping systems. Backfill should be tamped compactly in place. No rock shall be used in the first foot of the backfill. To meet H-20 highway loadings, there must be a minimum of 24 inches from top of jacket to grade of the compacted fill.

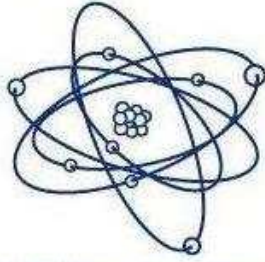

**ETF WEST LLC**  
 Division of Energy Task Force LLC

**Pre-insulated pipe**

7700 W Olive Ave - Peoria, AZ - 85345 - 623-878-4377 - 623-878-6683

**Table 1:** Specified Carrier Pipe / HDPE Jacket

Nominal Pipe Size	Minimum Insulation Thickness	Nominal Jacket Size	Nominal Jacket Size
1/2"	1.83	4.50	150 mils
3/4"	1.73	4.50	150 mils
1"	1.59	4.50	150 mils
1 1/4"	1.42	4.50	150 mils
1 1/2"	1.30	4.50	150 mils
2"	2.13	6.63	150 mils
2 1/2"	1.88	6.63	150 mils
3"	1.57	6.63	150 mils
4"	1.80	8.00	175 mils
5"	2.22	10.00	175 mils
6"	1.69	10.00	175 mils
8"	1.90	12.43	175 mils
10"	1.66	14.06	175 mils
12"	1.56	15.87	175 mils
14"	1.92	17.83	200 mils
16"	1.90	19.80	200 mils
18"	1.95	22.17	225 mils
20"	1.85	24.00	250 mils
24"	1.85	28.07	275 mils
30"	2.85	36.00	275 mils

**ETF LLC WARRANTY**

ETF LLC warrants its products only to the extent that it will replace those proved to have manufactured defects, within a one-year period from date of delivery. ETF must be provided an opportunity to inspect an alleged defective product and the installation application. This warranty does not provide for the expenses incurred for removal, re-installation or consequential damages arising from the defective material. There is no warranty other than that described above, and no one is authorized to issue any other warranty related to ETF LLC products.

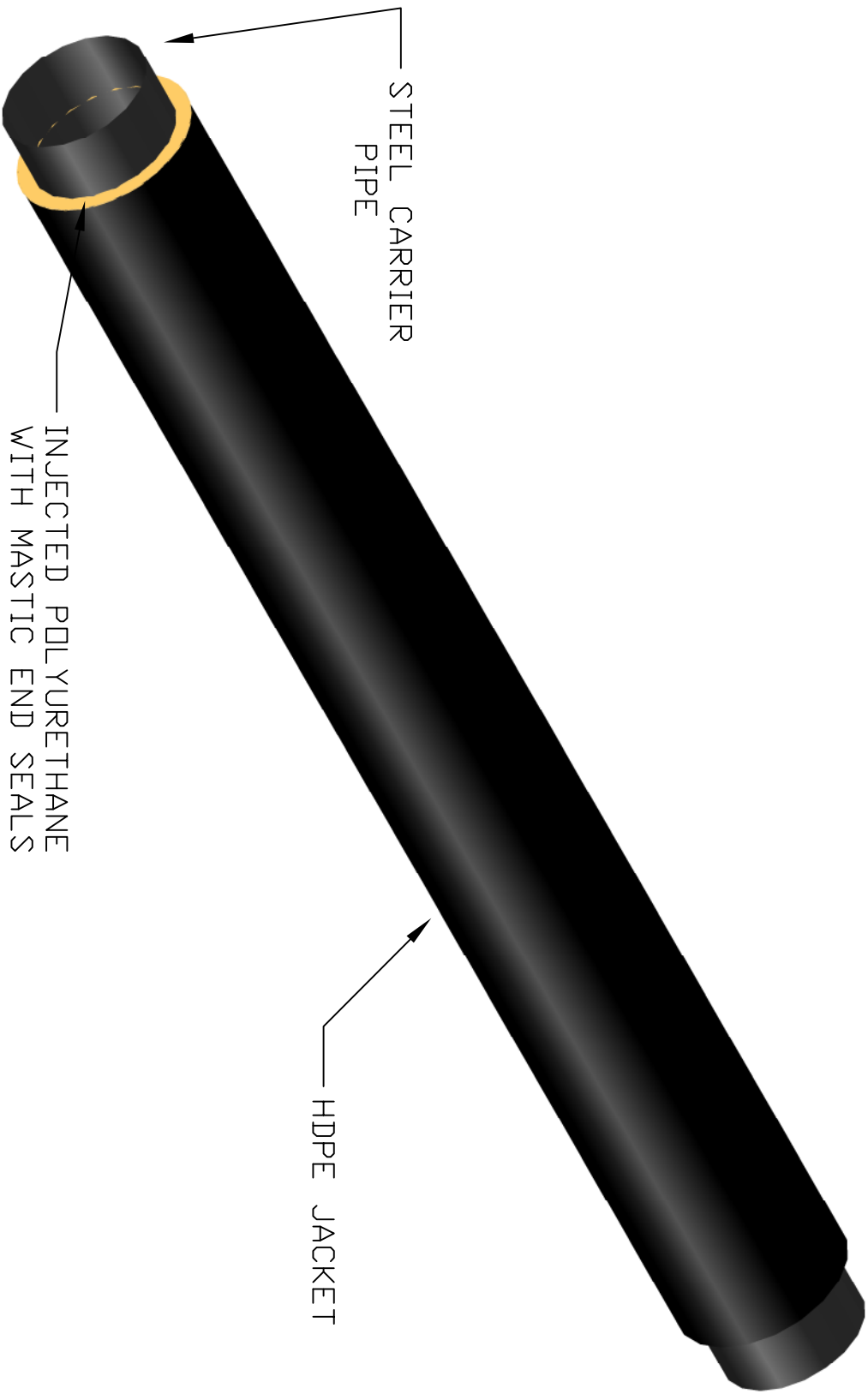

STEEL CARRIER PIPE

INJECTED POLYURETHANE WITH MASTIC END SEALS

HDPE JACKET

7700 W OLIVE AVE - PEORIA, AZ 85345 - 407-523-3770 - 407-523-3722

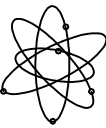

**ETF WEST LLC**  
**PRE-INSULATED PIPE**

SCALE NTS	STEEL X HDPE JACKET	DRAWN BY LG
DATE 4/22/16		
DWG #		

PIPE CAN BE 42' OR 21' LENGTHS

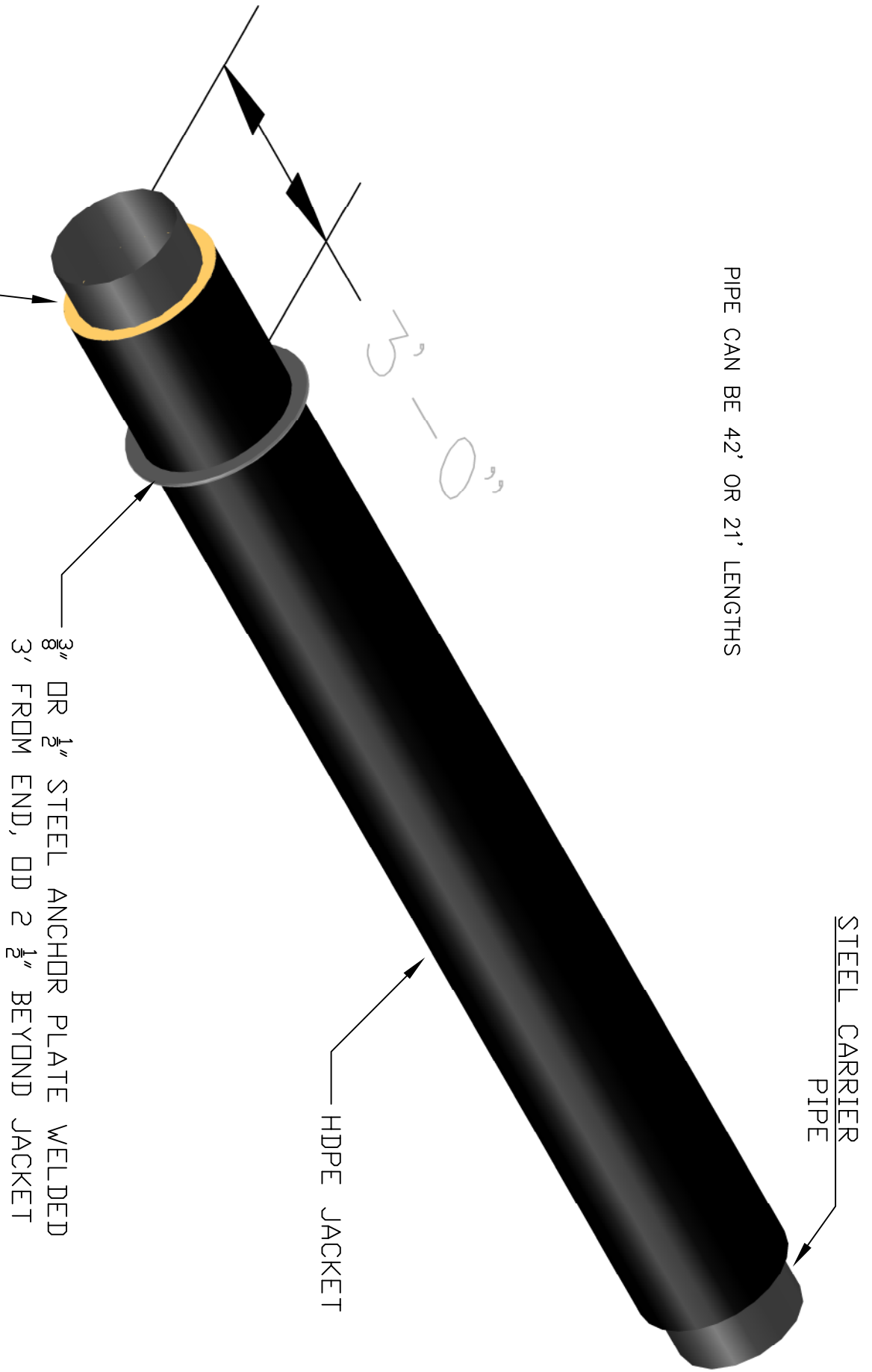

INJECTED POLYURETHANE WITH MASTIC END SEALS

3" OR 1 1/2" STEEL ANCHOR PLATE WELDED 3' FROM END, OD 2 1/2" BEYOND JACKET

HDPE JACKET

STEEL CARRIER PIPE

7700 W OLIVE AVE - PEORIA, AZ 85345 - 407-523-3770 - 407-523-3722

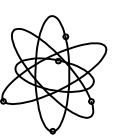

**ETF WEST LLC**  
**PRE-INSULATED PIPE**

SCALE  
NTS  
DATE 4/22/16

STEEL X HDPE JACKET

DRAWN BY  
LG  
DWG #

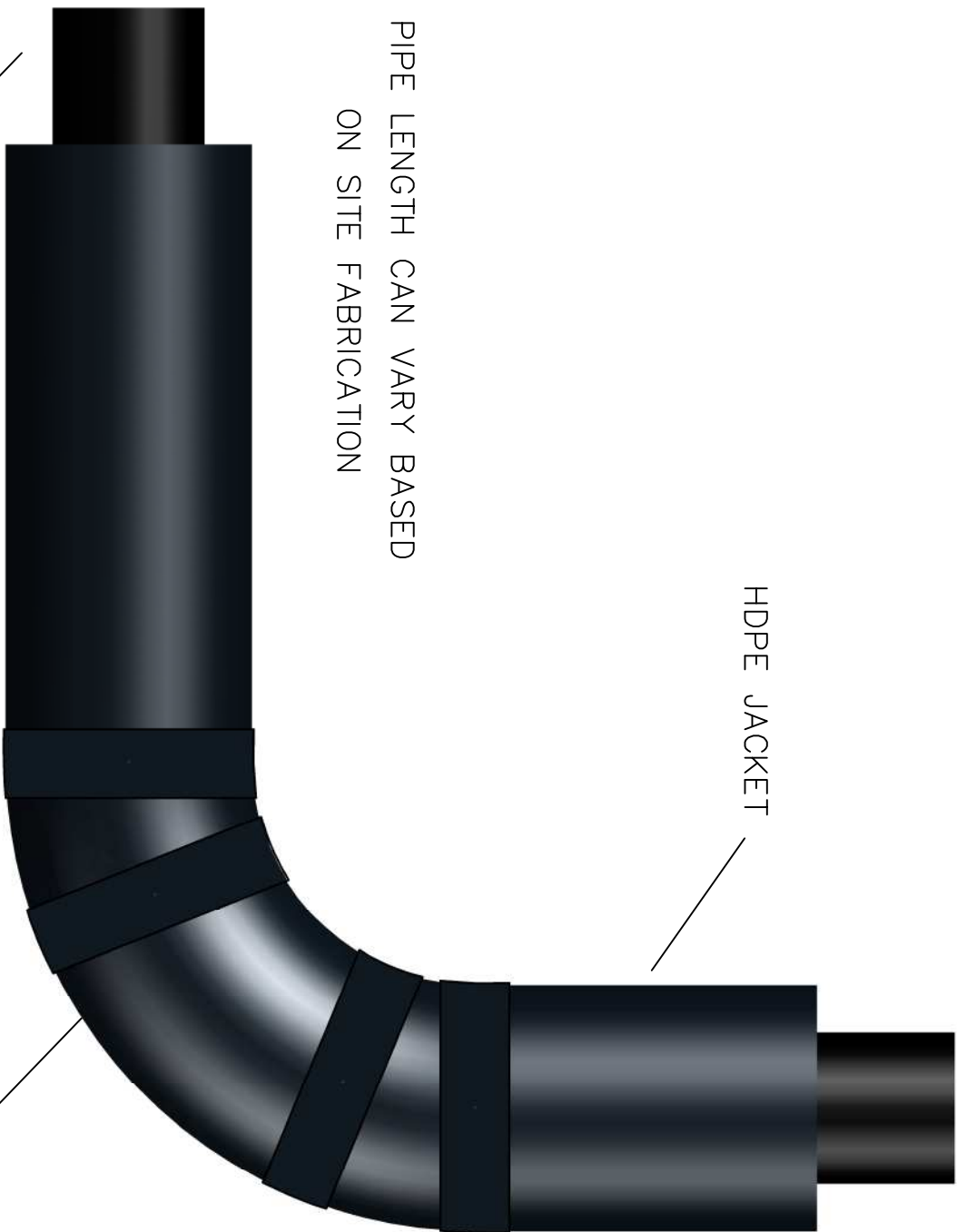

PIPE LENGTH CAN VARY BASED  
ON SITE FABRICATION

CARRIER PIPE AS SPECIFIED

HDPE JACKET

HEAT SHRINK APPLIED TO  
MITERED JACKET

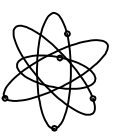

**ETE WEST LLC**  
**PRE-INSULATED PIPE**

7700 WEST OLIVE AVE - PEORIA, AZ 85345 - 623-878-4377 - 623-878-6683

SCALE  
NTS

DATE  
8/2/04

PRE-INSULATED 90

DRAWN BY  
LG

DWG #

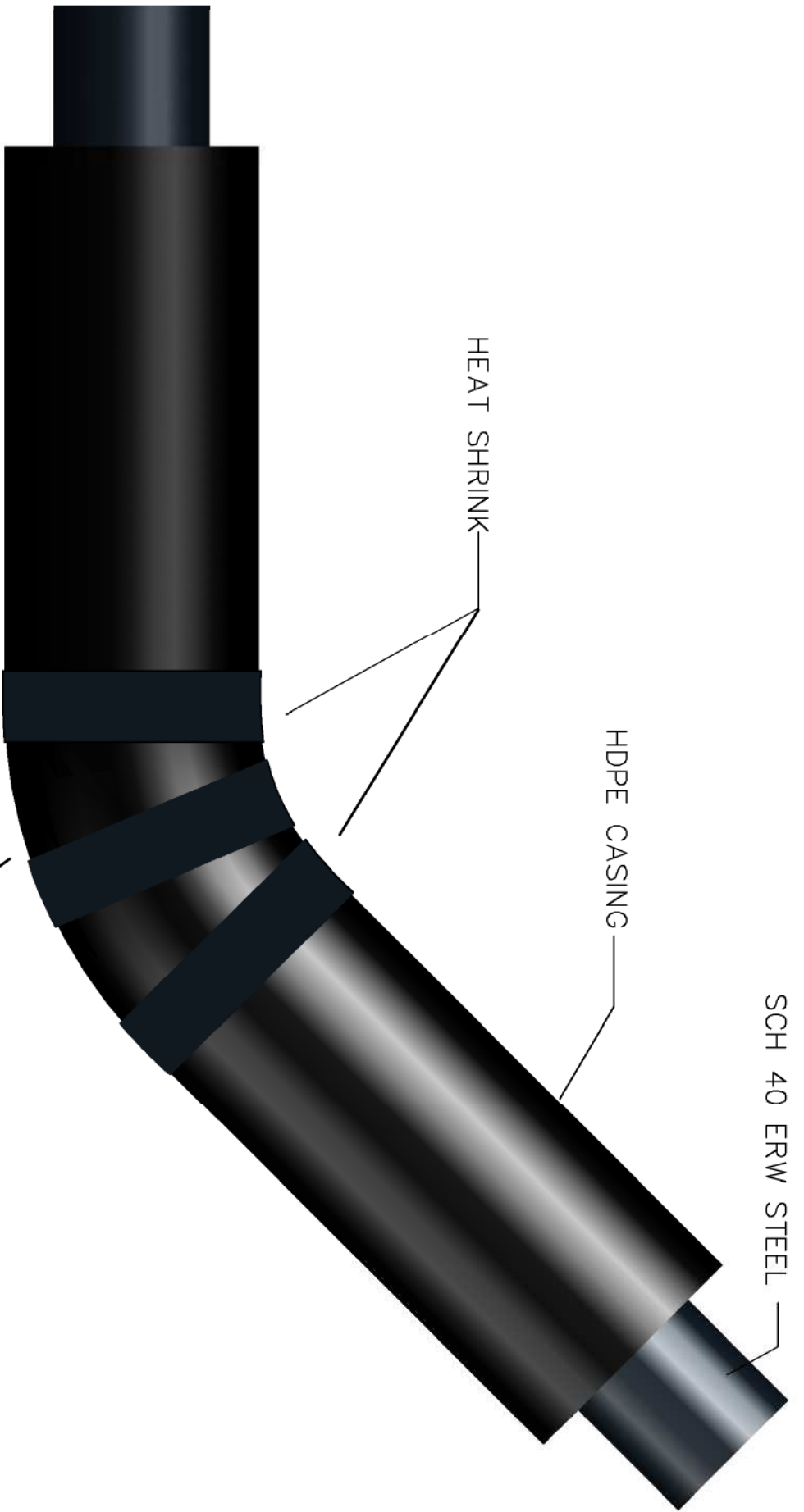

SCH 40 ERW STEEL

HDPE CASING

HEAT SHRINK

MITERED HDPE SLEEVE

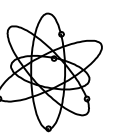

**ETF WEST LLC**  
**PRE-INSULATED PIPE**

7700 WEST OLIVE AVE - PEORIA, AZ 85345 - 407-523-3770 - 407-523-3722

SCALE NTS

PREFABRICATED

DRAWN BY LG

DATE 8/2/04

45 DEGREE ELBOW

DWG #

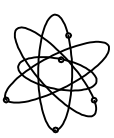
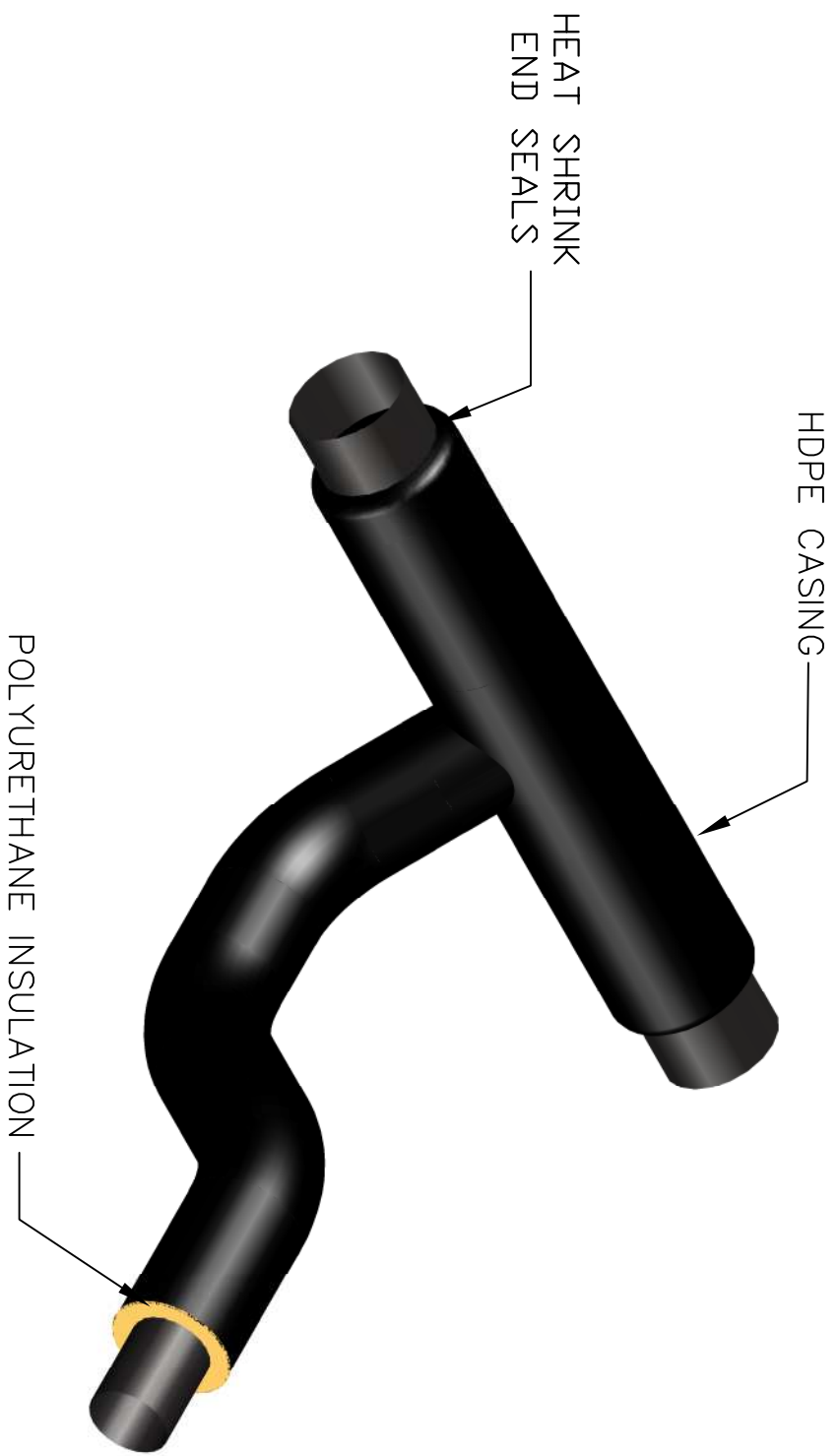

**ETF WEST LLC**  
**PRE-INSULATED PIPE**  
7700 WEST OLIVE AVE - PEORIA, AZ 85345 - 623-878-4377 - 623-878-6683

SCALE	NTS	DRAWN BY	LG
DATE	8/2/04		
PREFABRICATED CROSSOVER TEE		DWG #	

HDPE SLEEVE  
PRIOR TO INSULATING JOINT  
PRESSURE TEST SYSTEM



HDPE JACKET

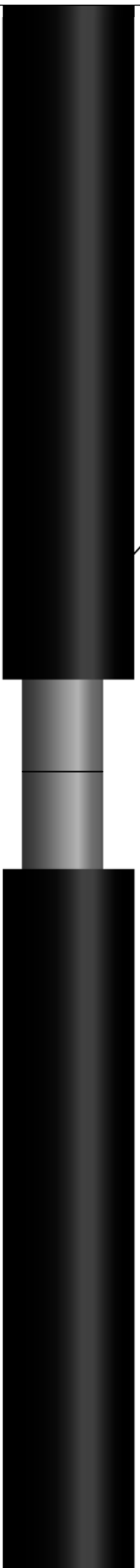

HDPE SLEEVE

HEAT SHRINK

COVER JOINT WITH HDPE SLEEVE  
WRAP SEAMS WITH HEAT SHRINK TAPE  
INSULATE JOINT WITH POUR FOAM

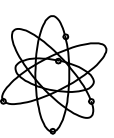

**ETF WEST LLC**  
**PRE-INSULATED PIPE**

7700 W OLIVE AVE - PEORIA, AZ 85345 - 407-523-3770 - 407-523-3722

SCALE  
NTS

DATE  
8/2/04

FIELD JOINT DETAIL

DRAWN BY  
LG

DWG #